

X- Mini Pump

- Max.vacuum level** : -93kpa (-697.5mmHg)
- Max.Flow rate** : 185NI/m (11.1m³/hr)
- Supply air pressure** : 4-6 bar Max. 7 bar
- Supply air type** : Dry compressed air
- Working temperature** : -20°C to +80°C
- Noise level** : 50 - 68dBA

Main advantages

These X-Mini range pumps are a compact and low weight design. Although they are the smallest of the VTX range they still use a Multi Stage Ejector principal for generating the vacuum. The X-Mini has the same external dimensions to that of the M-Mini, however the internal ejector system is different to enable higher levels of vacuum to be achieved. The X-Mini is a pump that bridges the gap between the High Flow VTM range and the High Vacuum VTH Range, giving a balance of the two. The housings are made from high grade plastic, making the pumps resilient to most hazardous vapours. Because the pumps are so small they can be mounted locally to the vacuum requirement, even directly onto the back of suction cups if required. Different vacuum port sizes are available with options for an integrally mounted exhaust or a 3/8" detachable versions. The pumps can be specified with a vacuum switch or a vacuum quick release module attached directly onto the pump. The pump can have seal materials options of Viton® & EPDM for corrosive and acidic applications.

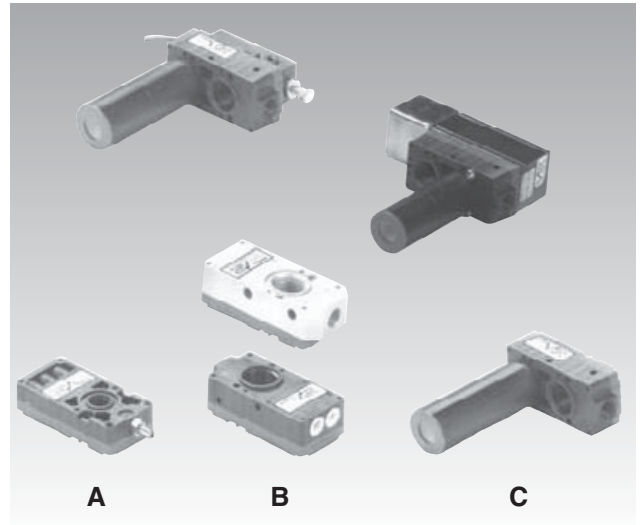

Order no.

VTX5 - B - A3 D3 - S1 - V

① ② ③ ④ ⑤ ⑥

① Model – Capacity equivalent to electricity motor pump size

• VTX5	- 0.05KW
VTX10	- 0.10KW
VTX20	- 0.20KW
VTX30	- 0.30KW

② Air Supply, Vacuum, Exhaust Port

	Air	Vacuum	Exhaust
A	M5-Ø6	G1/8"	Internal silencer
NA	M5-Ø6	NPSF1/8"	Internal silencer
• B	G1/8"	G3/8"	Internal silencer
BA	G1/8"	G3/8"	Internal silencer, connection plate-AL
NB	NPSF1/8"	NPSF 3/8"	Internal silencer
NBA	NPSF1/8"	NPSF 3/8"	Internal silencer, connection plate-AL
C	G1/8"	G3/8"	External silencer
NC	NPSF1/8"	NPSF 3/8"	External silencer

※ Standard pump model
 VTM5 - A, NA, B, BA, NB, NBA, C, NC VTM20 - B, BA, NB, NBA, C, NC
 VTM10 - A, NA, B, BA, NB, NBA, C, NC VTM30 - B, BA, NB, NBA, C, NC

③ Air supply control valve

A1	- AC110V
A2	- AC220V
• A3	- DC24V

④ Control valve & Solenoid terminal

- Piston valve
1 - DIN type without lead wire
- Piston valve
2 - DIN type with lamp without lead wire
- Piston valve
3* - Connector type with 0.3m lead wire & lamp
- Diaphragm valve
D1 - DIN type without lead wire
- Diaphragm valve
D2 - DIN type with lamp without lead wire
- Diaphragm valve
• D3* - Connector type with 0.3m lead wire & lamp

* : Only for DC24V

⑤ Vacuum switch / Quick release module

• S1	- Mechanical vacuum switch
Q1	- Quick release module : 12cm ³
Q2	- Quick release module : 30cm ³

※ Remark : For mechanical vacuum switch and air supply control valve available for vacuum pump B, BA, NB, NBA, C, NC type only.

⑥ Sealing

No mark	- Standard (NBR)
• V	- Viton®
E	- EPDM

Characteristics

Model	max. vacuum -kPa(-mmHg)	Max. vacuum flow (l/m)	air consumption (l/m)	noise level (dBA)	weight(g)	min hose inner Ø (within 2m)		
						air supply	vacuum	exhaust
VTX5	93 (697,5)	32	21,6-24	50 - 65	-	>2	>5	>8
VTX10		62	43,2-48	55 - 68	-	>2	>8	>10
VTX20		124	86,4-96	63 - 68	-	>4	>10	>12
VTX30		185	129,6-144	60 - 68	-	>6	>12	>15

* Remarks : type weight = VTX5-A(B,BA,NB,NBA,C,NC) : 26g(30,56,30,56,42,42)
 VTX10-A(B,BA,NBA,C,NC) : 28g(32,58,32,58,44,44)
 VTX20-B(BA,NB,NBA,C,NC) : 41g(79,41,79,53,53)
 VTX30-B(BA,NB,NBA,C,NC) : 60g(98,60,98,72,72)

Induce air in liters per minute (l/m)

Model \ -mmHg -kPa	0	75	150	225	300	375	450	525	600	675
	0	10	20	30	40	50	60	70	80	90
VTX5	32	18	9	8	7	6	5	3	1,2	0,45
VTX10	62	36	18	16	14	11	9	6	2,4	0,9
VTX20	124	72	35	32	27	22	18	12	4,8	1,8
VTX30	185	108	52	47	41	33	26	18	7,2	2,7

Time in seconds to evacuate to vacuum level (sec/l)

Model \ -mmHg -kPa	75	150	225	300	375	450	525	600	675
	10	20	30	40	50	60	70	80	90
VTX5	0,258	0,796	1,156	2,4	3,56	4,91	6,896	10,16	19,19
VTX10	0,129	0,398	0,758	1,2	1,78	2,455	3,445	5,08	9,594
VTX20	0,064	0,199	0,379	0,6	0,89	1,227	1,722	2,54	4,797
VTX30	0,048	0,149	0,284	0,44	0,673	0,917	1,287	1,906	3,595

Dimensional Information

5 VTX (10)-A(NA)

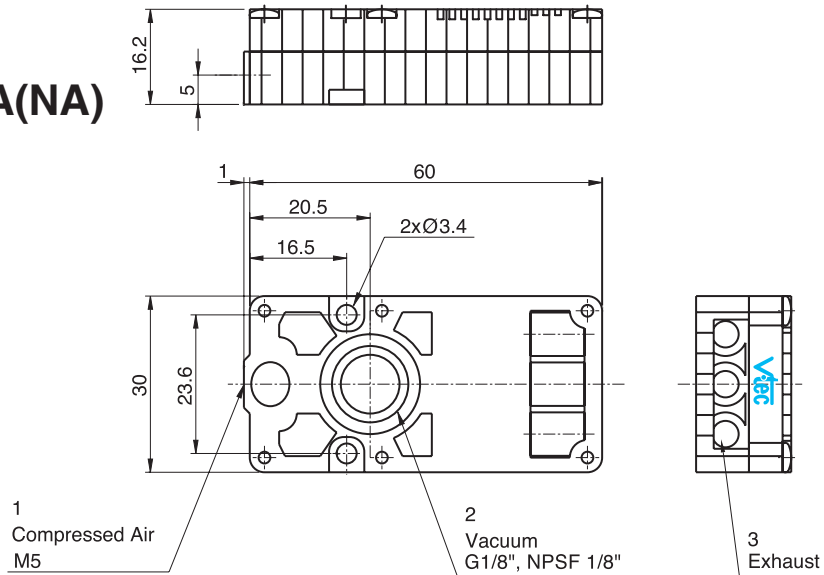

5 VTX (10)-B (BA, NB, NBA)

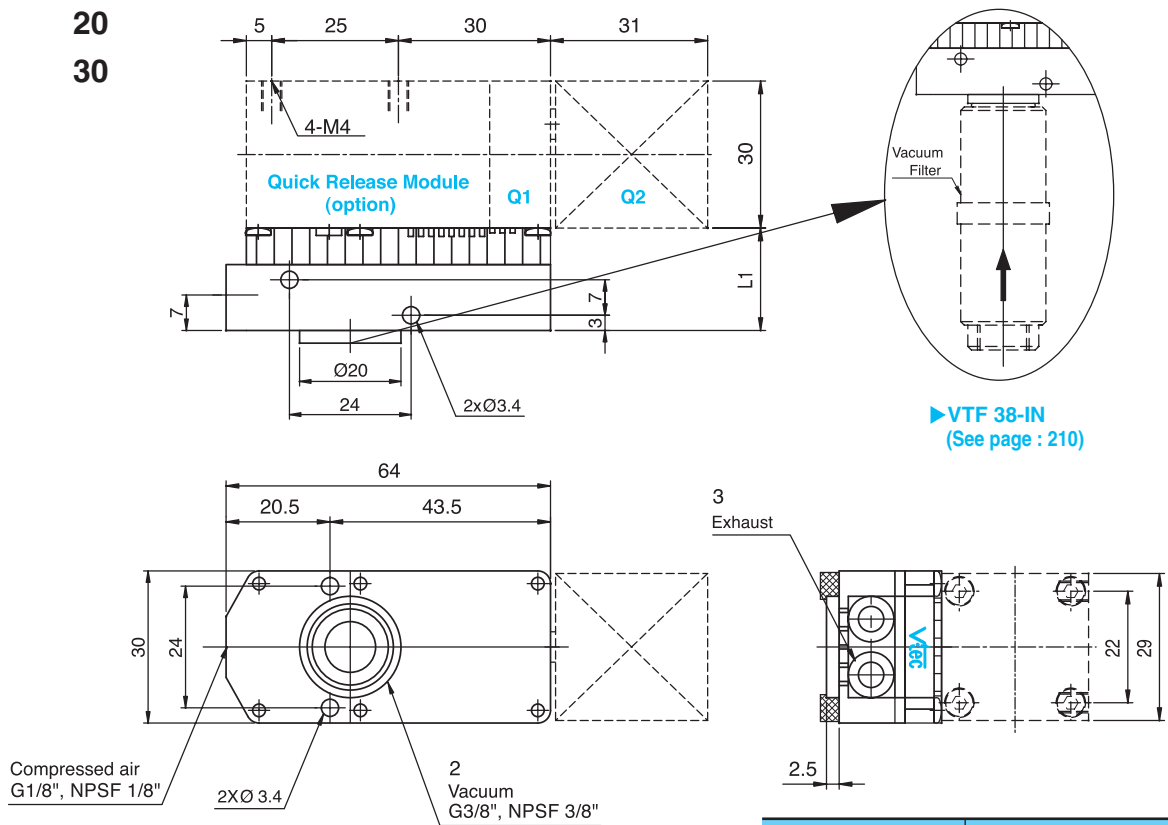

Model	L1 (mm)
VTX5	20.2
VTX10	20.2
VTX20	27.4

Dimensional Information

5
VTX (10)-C (NC)
20
30

with swith S1

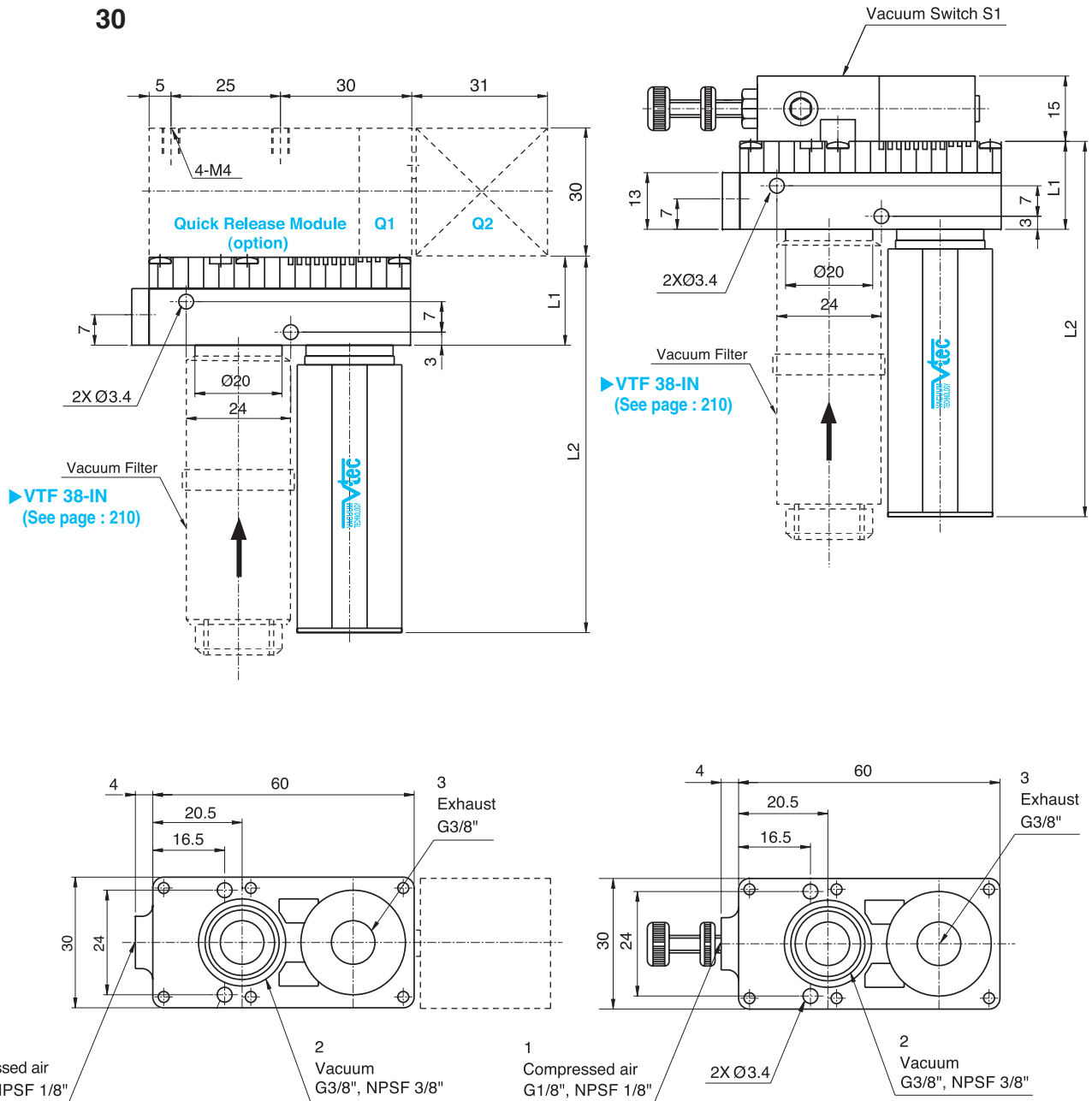

(mm)

Model	L1	L2
VTX5	20.2	86.2
VTX10	20.2	86.2
VTX20	27.4	93.4
VTX30	34.6	100.6